



長 **CCP** 春



CCP Group & LCP Introduction

-- **LONGLITE® LCP** (Liquid Crystalline Polymer)



2013/07/05

Agenda

- 1. CCP Group Overview**
- 2. Introduction of CCP LCP**
 - 2.1 Development**
 - 2.2 Manufacture Process**
 - 2.3 Grade and Property**
 - 2.4 Counter-grade**
- 3. Package and UL certificate**
- 4. LCP Application**
- 5. QA lab analysis facilities**
- 6. Recycled Test Information**
- 7. Discussion**
- 8. Appendix**



Brief Information and History of CCP

- Founded in 1949
- Founders : Su Hon Lin, S. Y. Tseng, M. K. Liao,
- Main Affiliates: Chang Chun Plastics Co., Ltd.
Chang Chun Petrochemical Co., Ltd.
Dairen Chemical Co., Ltd.
- Private Owned, Headquartered in Taipei
- One of the leading chemicals & electronic materials company in Taiwan
- Employee: 8,500
- Sales Revenue and Profit:

CCP Group (MN USD)	2001	2002	2003	2004	2005	2006	2007	2008	2009	2010	2011	2012
Sales Revenue	1,210	1,503	1,731	2,303	2,728	3,617	4,210	4,380	3,733	5,519	6,147	6,237
Net Income	98.3	126	125	202	228	342	565	171	187	615	738	391

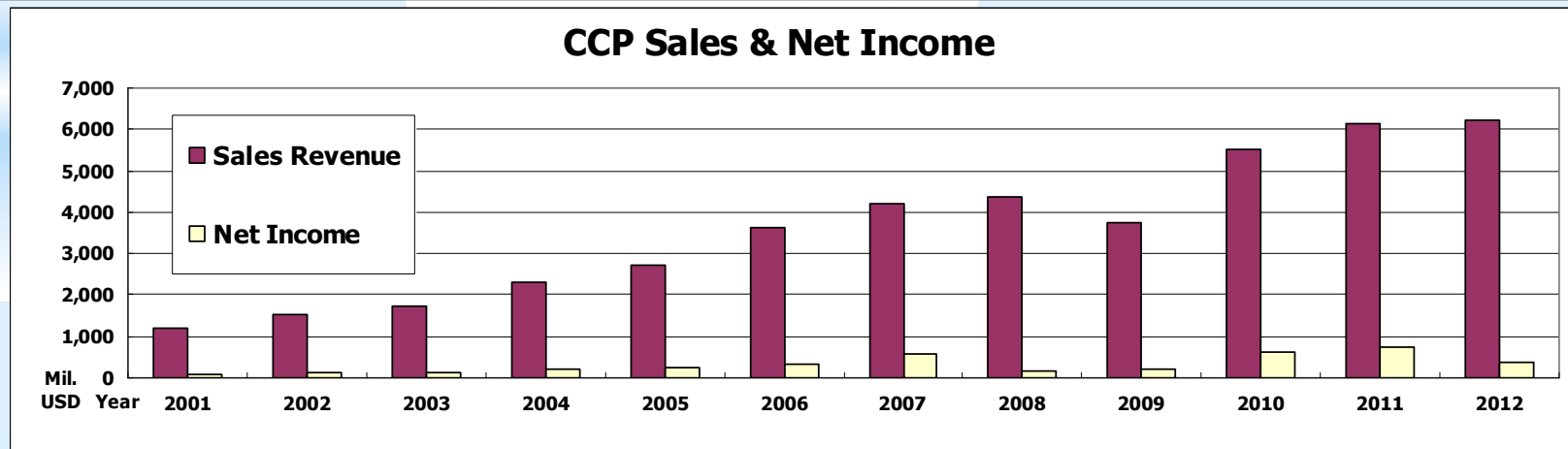

Production facilities in the world





• History and Development of CCP LCP

- 1999** Started research of liquid crystal polymer (LCP) in Hsinchu, Taiwan.
- 2003** Built a pilot plant for type I LCP polymer of HDT higher than 300°C.
- 2007** Commenced research raw material for LCP: PHBA and Bi-phenol
- 2008.12** Completed a plant for LCP polymer and compound with **polymer capacity of 800 ton/year** and **compound's of 2,000 ton/year** in Hsinchu, Taiwan.
- 2009** Started sales of CCP LCP-300(HDT=300°C) compound for bobbin application.
- 2010.10** Initiated sales of CCP LCP-270(HDT=270°C) and LCP-300 compound for connector application.
- 2011.3** Successfully open business to several Taiwanese connector customers
- 2012.2** Successfully to sell to European customer to make home appliance
- 2012.3** Increased production line 2 of LCP neat polymer to **1,800 ton/year**.
PHBA factory began operation of **4000 ton/year** in Mailiao, Taiwan.
Biphenol has been started pilot run.
- 2012.10** **New base polymers are developed to achieve both high flowability and high heat resistance.**

LCP Polymer Manufacturing Process

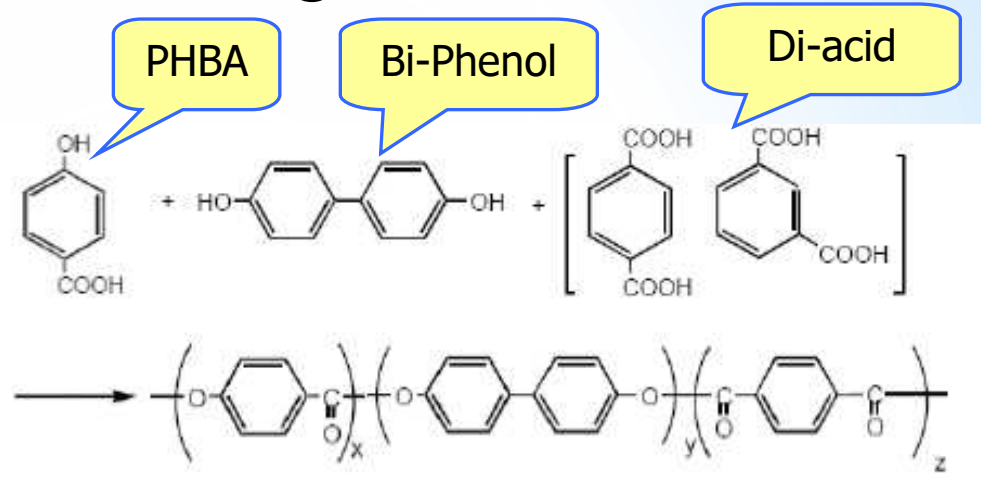
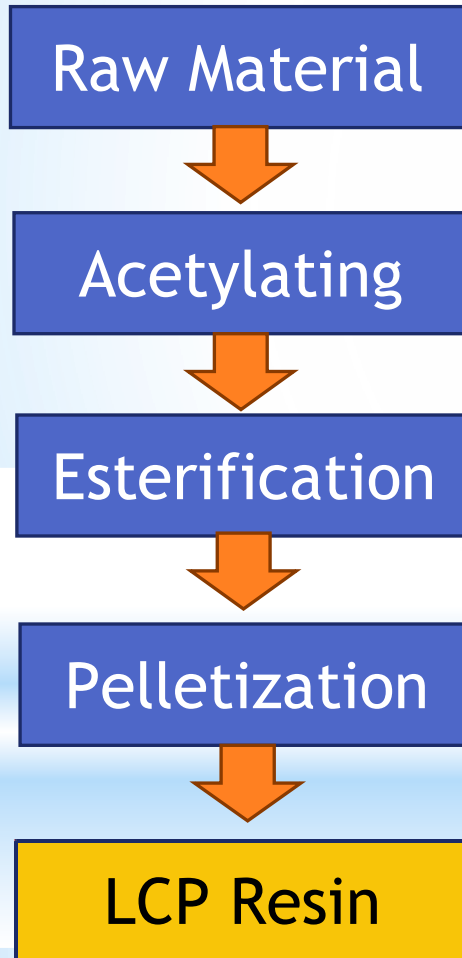

LCP Compoundinng Process

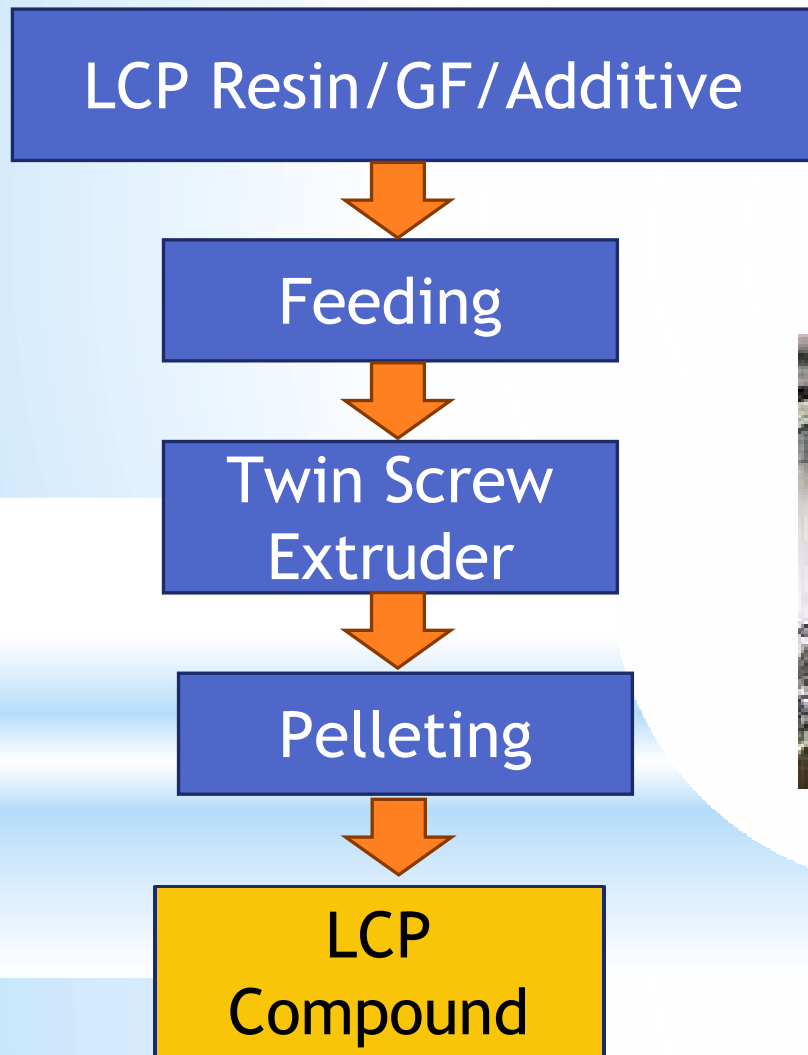

CCP ascendancy of LCP

- * CCP is backward intergrated in feedstock, so have already started production facilities of PHBA & Bi-phenol, the key monomers of LCP. It's similar with 1,4-BDO for PBT and phenol/formalin for PMC.
- * CCP owns synthesis technology of liquid crystal polymer, and make super high heat resistance HDT>300°C LCP base polymer.
- * CCP owns much experience of compounding from PBT/PET/PMC compound, and can make customized grades according to product design.

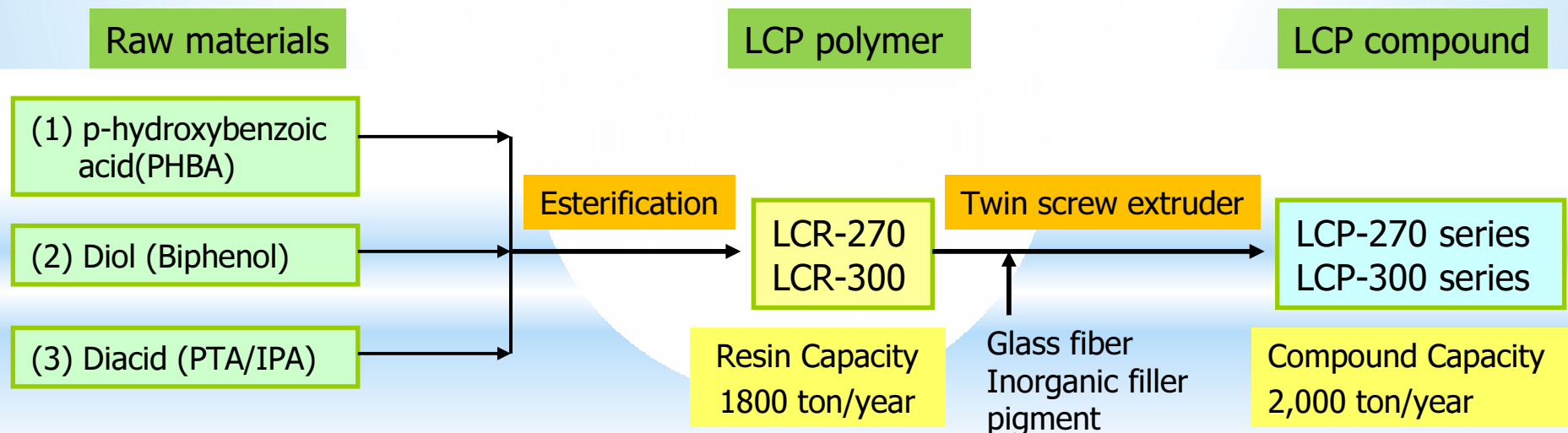

Liquid crystal polymer

LCP is classified as type I、type II and type III according to the difference of thermal resistant (HDT).

Item	Heat deformation temp.(HDT)	Classification
High thermal resistant	$\geq 280^{\circ}\text{C}$	Type I
Medium thermal resistant	$240\sim 280^{\circ}\text{C}$	Type II
Low thermal resistant	$\leq 240^{\circ}\text{C}$	Type III

Product trends:

- ✓ Lead free solder resistance
- ✓ Environmental-friendly
- ✓ Thin wall & Fine-Pitch

"LONGLITE[®] LCP"

Has both Type I and Type II
UL94 V-0:No need flame retardant
and Good thin-wall flowability.



LONGLITE[®] LCP Grade & Features

- Type II: LCP-270 Series (HDT=270°C)

Grade	B3G / N3G*	B3TL/ N3TL	B4TL/ N4TL	B5TL/ N5TL
Filler Content	30% Glass Fiber	35% Glass Fiber/ Mineral Fiber	40% Glass Fiber/ Mineral Fiber	45~50% Glass Fiber/ Mineral Fiber
HDT	270 °C	270 °C	270 °C	270 °C
Features	General Grade High Flexibility	Low Warp High Flow	Low Warp	Low Warp
Application	SATA / RJ SIM CARD	FPC / DDR3 SD Card	FPC/ SD Card DDR3	FPC/ SD Card DDR3

* B: Black / N: Natural Color ; 3 : Filler content
G / GF: Glass fiber T/MF: Mineral fiber



LONGLITE[®] LCP Grade & Features

- Type I: LCP-300 Series

Grade	B3G / N3G*	B4G/ N4G	B4TL/ N4TL	B5TL/ N5TL	B4M
Filler Content	30% Glass Fiber	40 Glass Fiber% (Milled)	40% Glass Fiber/ Mineral Fiber	48% Glass Fiber/ Mineral Fiber	40% Mineral Fiber
HDT	310 °C	300 °C	285 °C	285 °C	265 °C
Features	General type High Flexibility	Heat Resistance High Flow	Low Warpage High Flow	Low Warpage Heat Resistance	Heat Resistance
Application	SATA SIM CARD	Switch/ SATA PCI / PCMCIA Bobbin	DDR3 SD Card FPC	DDR3 SD Card FPC	Cookware

* B: Black / N: Natural Color ; 3/4 : Filler content
G / GF: Glass fiber T/MF: Mineral fiber



CCP LCP Counter-Grade

LCP grade	Filler Ratio	Property	Poly/ Ticona	Ticona	S.C.	日石化	DIC	UENO
270B/N3G*	30%GF**	Flexibility	E130i	6130	E6006			6030G
270B/N3TL	35%GF/MF	Low Warpaga/ High Flow	E471i E473i		E6807		LD235	(2040GM)
270B/N4TL	40%GF/MF	Low Warpaga	E463i	6244 (7240)	E6808			6040GM
270B/N5TL	45~50%GF/MF	Low Warpaga	E481i			MG350		
300B/N3G	30%GF	Heat Res. /Flexibility	(S135)***	7130				
300B4G	40%GF	Heat Res. /Flexibility		(7145L)	E4008	HM402		
300B4TL	40%GF/MF	Heat Res./ Low Warpaga	(E481i)			(MG350)		
300B5TL	48%GF/MF	Heat Res./ Low Warpaga				(MG350)		
300B4M	40%MF	Low Flow Mark		7340				

* B: Black / N: Natural Color ; 3/4/5: Filler content roughly

** G/GF: Glass fiber T/MF: Mineral fiber

***():Higher Temp Grade

LCP-270B3G vs. P Co.,Ltd



* GF: Glass fiber

Item	Unit	Standard	270B3G	P 社材
			CCP analysis	
Filler content	%	GF*	29.8	29.8
Specific Gravity	---	ISO1183	1.61	1.61
	---	ASTM D792	1.62	1.61
Tensile Strength	MPa	ISO 527	141	135
		ASTM D638	130	128
Tensile Elongation	%	ISO 527	1.8	1.8
		ASTM D638	1.6	1.6
Flexural Strength	MPa	ISO 178	170	170
		ASTM D790	190	191
Flexural Modulus	GPa	ISO 178	11.2	11.2
		ASTM D790	12.1	12.4
Izod Impact (notched)	J/m	ISO 180	76	77
		ASTM D256	117	114
HDT DTUL (1.82MPa)	°C	ASTM D648	276	276
Bar Flow	mm	0.3mm/350 °C	46	47

1. The analysis data listed above are results obtained from the testing of CCP standard specimens using the stated test procedures, with said specimens molded under CCP laboratory conditions from representative samples of the product.

2. P社材 : E 130I Bk

LCP-270B3G vs. P Co.,Ltd Viscosity



Viscosity vs Temp (Shear rate= 1000sec^{-1})

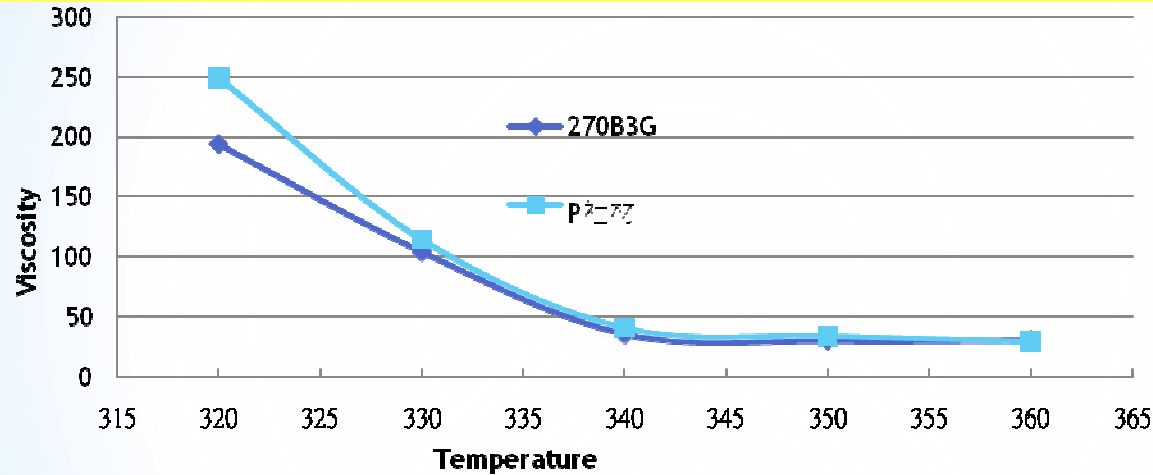

Viscosity vs Shear Rate @ 340°C

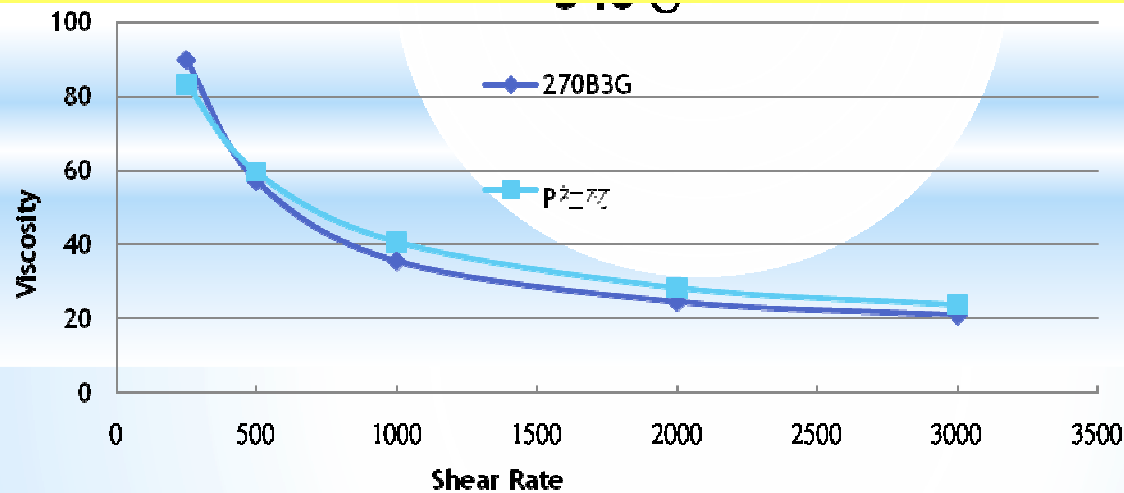

LCP-270B3TL vs. P社材 物性比較



* GF: Glass fiber / MF: Mineral filler

Item	Unit	Standard	270B3TL	P社材
			CCP analysis	
Filler content	%	GF/MF*	35	35
Specific Gravity	---	ISO1183	1.66	1.67
	---	ASTM D792	1.67	1.68
Tensile Strength	MPa	ISO 527	124	125
		ASTM D638	118	120
Tensile Elongation	%	ISO 527	2.0	2.1
		ASTM D638	1.8	1.9
Flexural Strength	MPa	ISO 178	157	158
		ASTM D790	171	173
Flexural Modulus	GPa	ISO 178	10.2	10.1
		ASTM D790	11.7	11.7
Izod Impact (notched)	J/m	ISO 180	63	66
		ASTM D256	76	83
HDT DTUL (1.82MPa)	°C	ASTM D648	270	270
Bar Flow	mm	0.3mm/350 °C	56	57

1. The analysis data listed above are results obtained from the testing of CCP standard specimens using the stated test procedures, with said specimens molded under CCP laboratory conditions from representative samples of the product.

2. P社材 : E 471I Bk

LCP-270B3TL vs. P Co.,Ltd. Viscosity



Viscosity vs Temp (Shear rate= 1000sec^{-1})

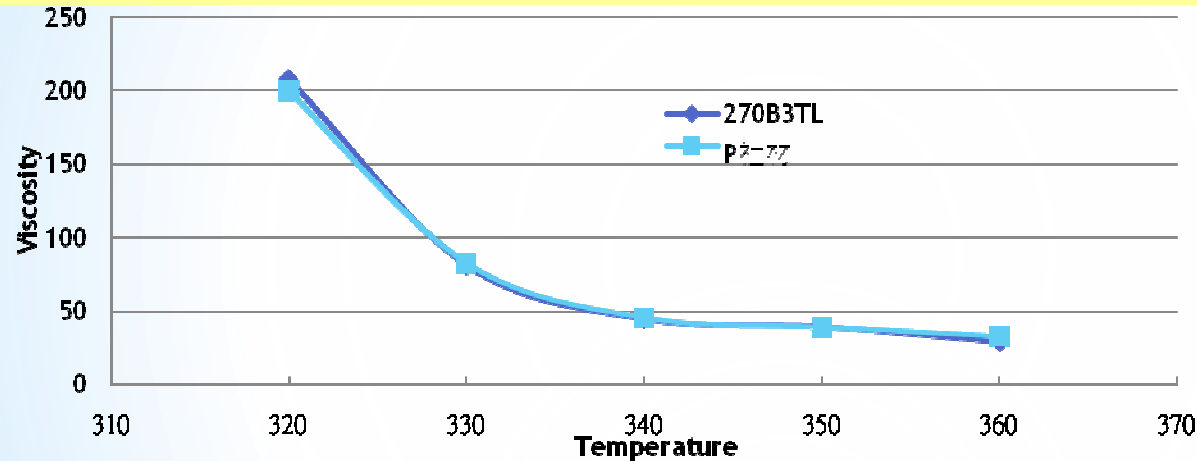

Viscosity vs Shear Rate @ 340°C

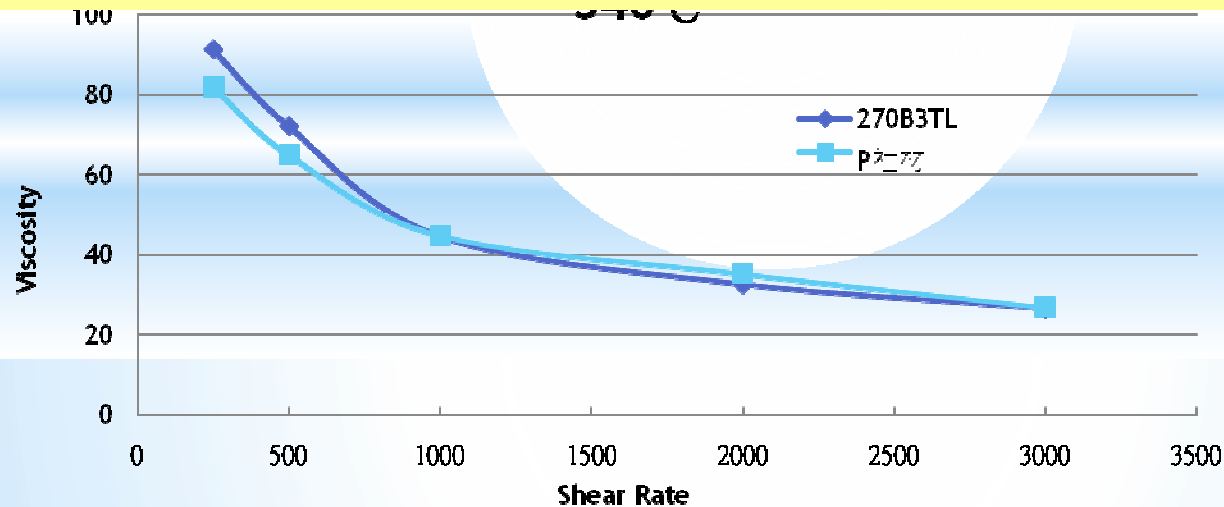

LCP-270B5TL vs. N Co.,Ltd.



* GF: Glass fiber / MF: Mineral filler

Item	Unit	Standard	27B5TL	N社材
			CCP analysis	
Filler content	%	GF/MF*	45(1:1)	47(1:1)
Specific Gravity	---	ASTM D792	1.76	1.77
Tensile Strength	MPa	ASTM D638	91	86
Tensile Elongation	%	ASTM D638	1.7	1.6
Flexural Strength	MPa	ASTM D790	143	136
Flexural Modulus	GPa	ASTM D790	11.0	10.4
Izod Impact (notched)	J/m	ASTM D256	75	78
HDT DTUL (1.82MPa)	°C	ASTM D648	280	280
Bar Flow	mm	0.3mm/350 °C	47	46

1. The analysis data listed above are results obtained from the testing of CCP standard specimens using the stated test procedures, with said specimens molded under CCP laboratory conditions from representative samples of the product
2. N社材 : MG 350 BPRL

LCP-270B5TL vs. N Co.,Ltd. Viscosity



Viscosity vs Temp (Shear rate=1000sec⁻¹)

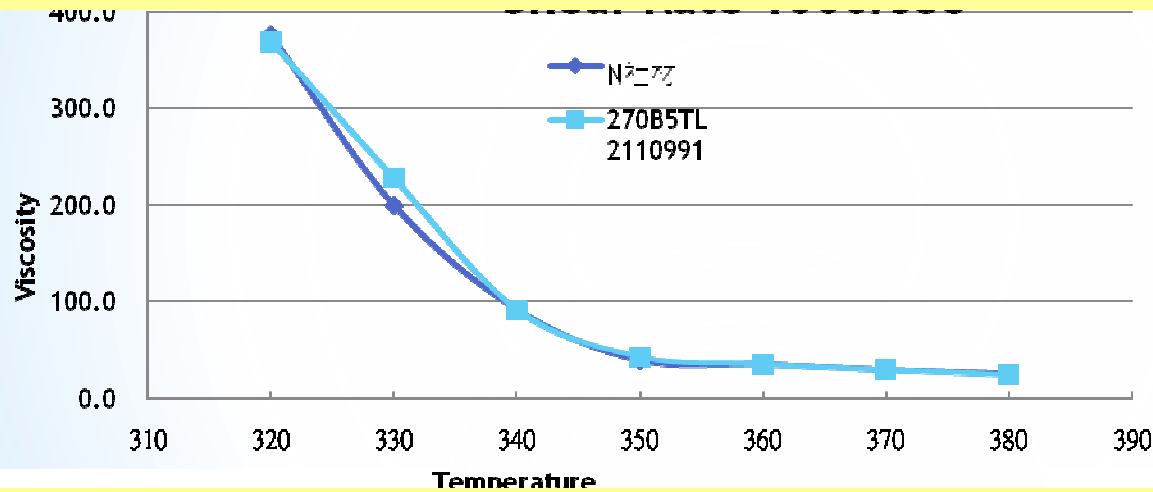

Viscosity vs Shear Rate @ 340°C

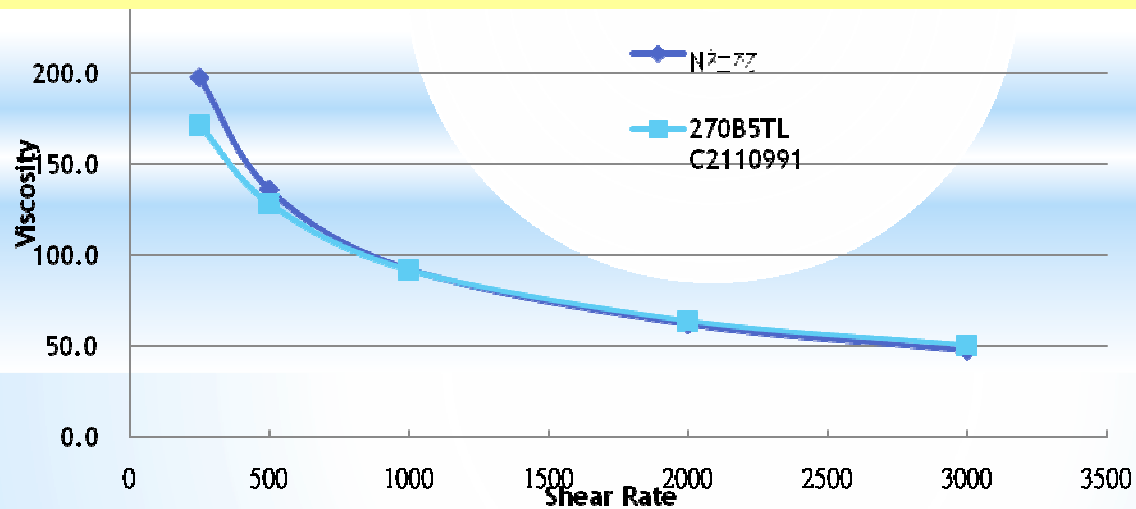

* Package and Molding Parameters



Definition of Lot No.

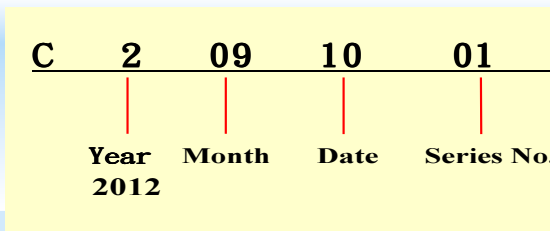

成型條件 (Molding Parameters) :

成型條件建議如下表，使用前先將 LCP-300/ LCP-270 成型材料以 140°C × (4~16)hr 烘乾後再射出成型，避免產品 Gas 問題產生。

To avoid the gas problem , Drying the material under 140°C × (4~16) hrs condition before injection

項目 / Item	單位 Unit	LCP-300	LCP-270
料筒溫度 Cylinder Temperature			
前段 Front(Nozzle)	°C	380±10	340±10
中段 Middle(Feed section)	°C	360±10	320±10
後段 Rear(Feed section)	°C	340±10	300±10
模具溫度 Mold Temperature			
移動模 Moving	°C	80 (60~120)	
固定模 Fixed	°C	80 (60~120)	
射出條件 Injection Condition			
射出壓 Injection Pressure	Kg/cm ²	1000 (1000-1400)	
二次壓 2nd Injection Pressure	Kg/cm ²	500 (300-700)	
螺桿轉速 Screw Pressure	rpm	60 (40-120)	

Appendix: **LONGLITE® LCP-270 TL / UL Certification**



Component - Plastics

E59481

CHANG CHUN PLASTICS CO LTD

7TH FL, 301 SONGKIANG RD, TAIPEI 104 TW

270(X1)(X2)TL

Liquid Crystal Polymer (LCP), "LONGLITE", furnished as pellets

Color	Min Thk (mm)	Flame Class	HWI	HAI	RTI	RTI	RTI
					Elec	Imp	Str
NC, BK	0.3	V-0	4	1	130	130	130
	1.0	V-0	1	1	130	130	130
	3.0	V-0	1	0	130	130	130

Comparative Tracking Index (CTI): **3**

Inclined Plane Tracking (IPT): -

Dielectric Strength (kV/mm): -

Volume Resistivity (10^x ohm-cm) : -

High-Voltage Arc Tracking Rate
(HVTR): **1**

High Volt, Low Current Arc Resis (D495): -

Dimensional Stability (%): -

(X1) - Maybe replace by one letter N representing Natural color or B representing Black color

(X2) - Maybe 3-5 indicating the content of talc and glass fiber filler from 30% to 50% by weight

Appendix: **LONGLITE® LCP-300 UL Certification**



Underwriters
 Laboratories

Component Plastics Recognition

Component - Plastics

E59481

CHANG CHUN PLASTICS CO LTD

7TH FL, 301 SONGKIANG RD, TAIPEI TW

LCP-300

Liquid Crystal Polymer (LCP), "LONGLITE", furnished as pellets

Color	Min Thk (mm)	Flame Class	HWI	HAI	RTI Elec	RTI Imp	RTI Str
NC,BK	0.3	V-0	-	-	130	130	130
	0.8	V-0	3	2	130	130	130
	3.0	V-0	0	3	130	130	130

Comparative Tracking Index (CTI): -

Dimensional Stability (%): -

High-Voltage Arc Tracking Rate (HVTR): -

High Volt, Low Current Arc Resis (D495): -

Dielectric Strength (kV/mm): -

Volume Resistivity (10⁹ohm-cm): -

ANSI/UL 94 small-scale test data does not pertain to building materials, furnishings and related contents. ANSI/UL 94 small-scale test data is intended solely for determining the flammability of plastic materials used in the components and parts of end-product devices and appliances, where the acceptability of the combination is determined by UL.

Report Date: 2005-07-22









Last Revised: 2007-04-30

Underwriters Laboratories Inc®



LONGLITE[®] LCP Application



Field	Products	Examples
Computer Electronics: Connectors	DDR	See Next Page
	Socket	
	FPC	
	SATA	
	HDMI / RJ45	
	Transformer Bobbin	
	Card	
Comsumer Electronics	Board to Board	
	Lens frame	
	Battery Cap	
Automotive	Fog Lamp frame	
		
Home Appliance	Lamp Socket	  
	Handle of Oven	
	Food Container	
Lighting	LED Reflector	 
	LED lampholder	
	Heat Conducting Sink	

LONGLITE[®] LCP Application



FPC

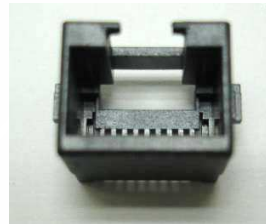

RJ45



PCI

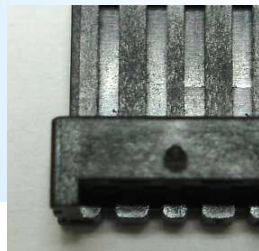

USB



SATA



Battery Case



DDR3

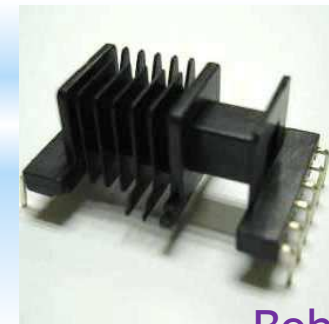

Bobbin

LCP Quality Analysis

- ✓ Thermal Analysis
- ✓ Specific Gravity / Ash
- ✓ Strength- Material Tester & IZOD Impact
- ✓ HDT
- ✓ Electrical - DS/Dk/Df/D495/CTI
- ✓ Solder Resistance
- ✓ ICP & XRF

Thermal Analyzer

Thermal Gravimetric Analyzer (TA Q500)



Differential Scanning Calorimeter (TA Q200)

Melting Point



Specific Gravity / Ash Tester

SG (ASTM D792)



Ash (ASTM D482)



Material Tester

Tensile and Flexural Properties

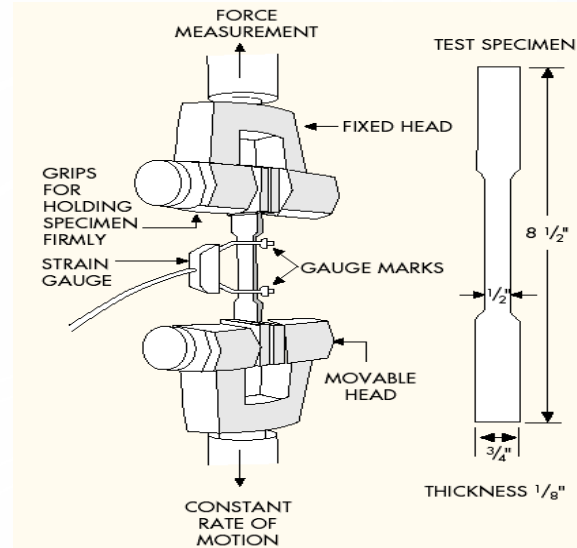

曲折強度及伸長率
Tensile Strength
& Elongation
(ASTM D638)

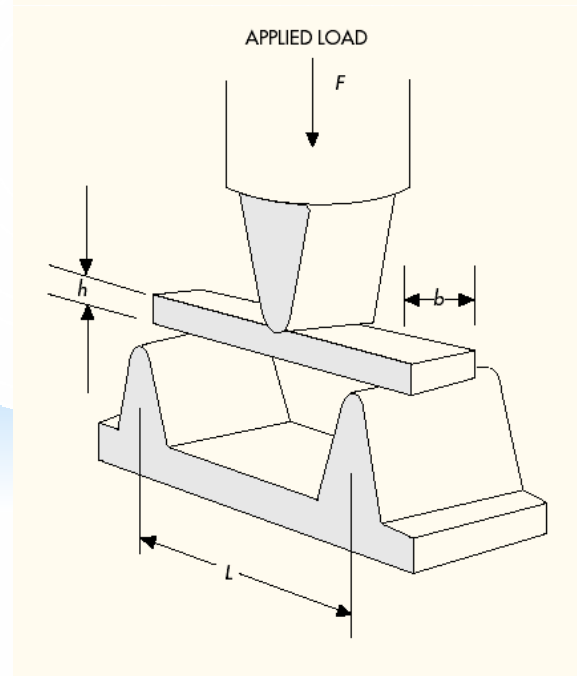

曲折長度及彈性率
Flexural Strength
& Modulus
(ASTM D790)

IZOD Impact Tester

Izod Impact Strength (ASTM D256)

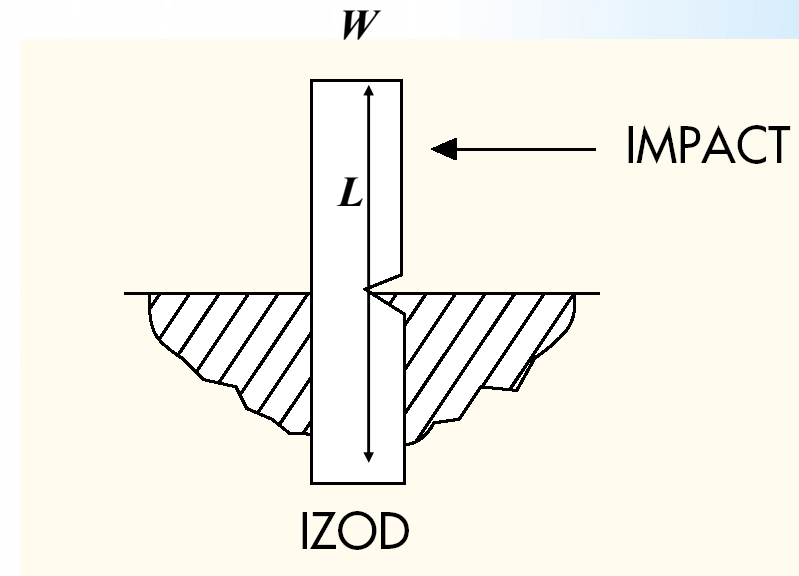

HDT Analysis

Heat Deflection Temperature Tester (ASTM D648)

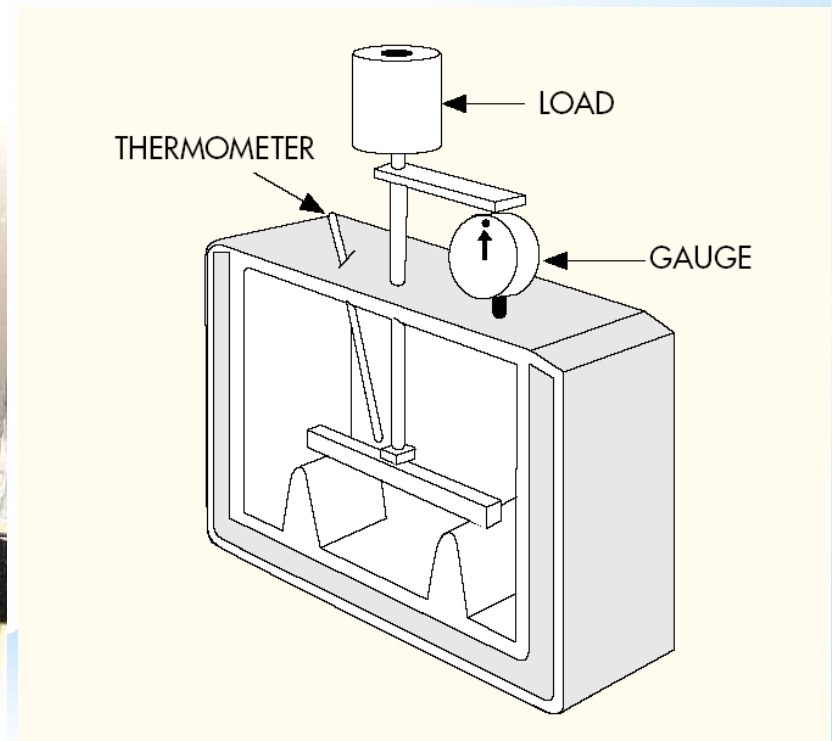

Electrical Analysis

*Dielectric Strength Tester
(ASTM D149)
>> Dielectric Strength*



*Precision Impedance Analyzer
(ASTM D150)
>> Dielectric Constant & Tangent*



Solder Resistance

Soldering Resistance



IR – Reflow Test



ICP & XRF RoHS & Component

*Inductively Coupled Plasma –
Atomic Emission Spectra (IEC 62321)
>> RoHS Requirement*

*XRF
>> RoHS Requirement*





LCP Recycled Test Information

* **LCP-270B3G 30% recycled vs. Viscosity**

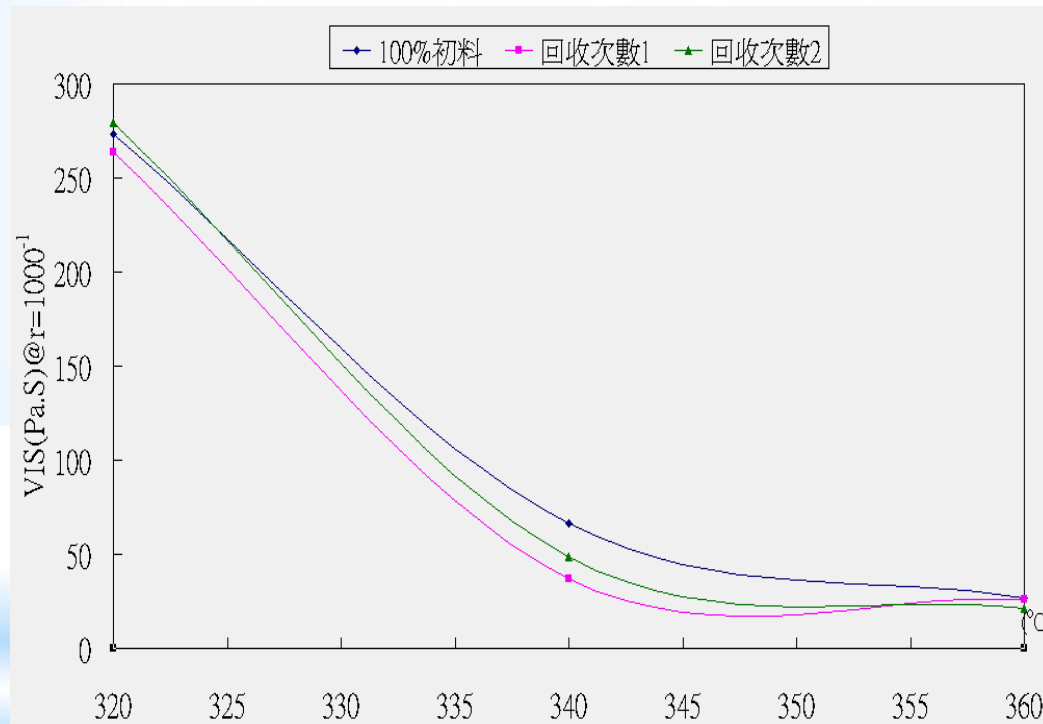

* **LCP-270B3G 回收料添加黏度降低現象(與一般塑料回收同)**

LCP-270B3G 30% recycled vs. Tensile Strength

Mold Shrinkage



CCP

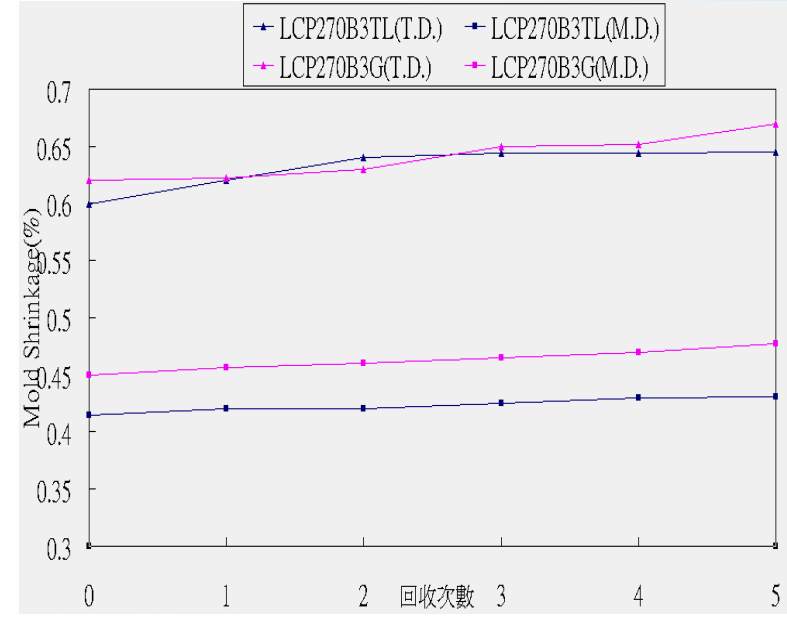
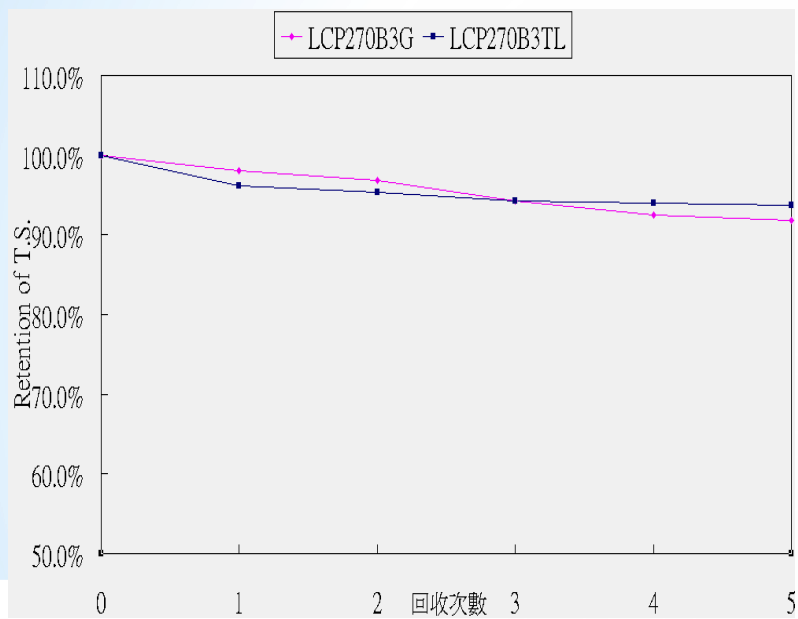

住化

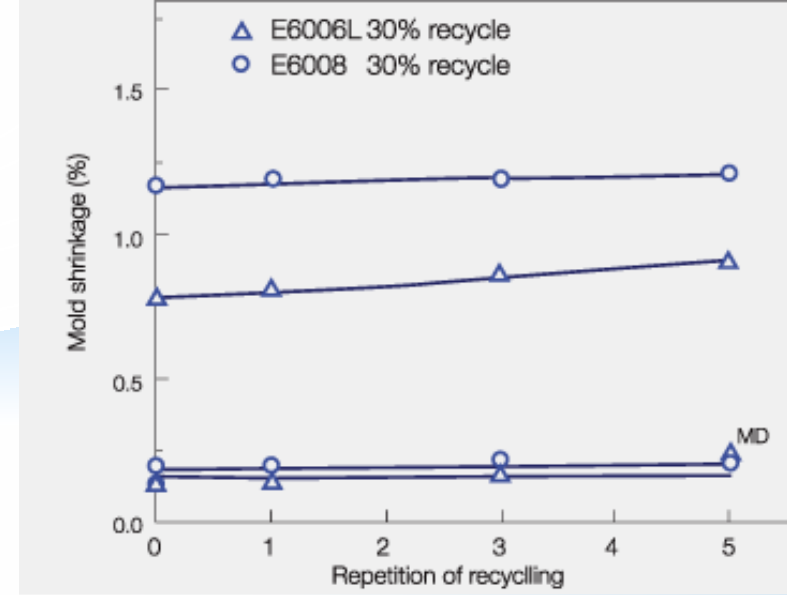
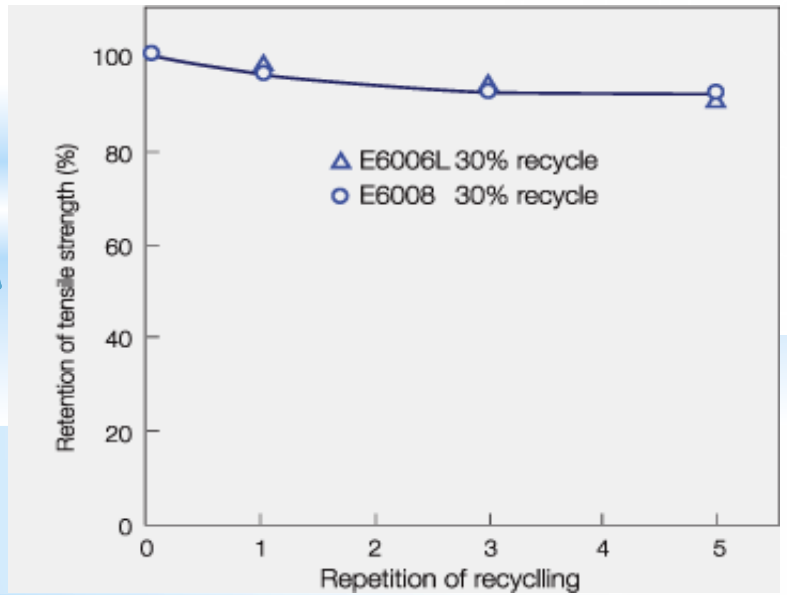

**Thank you
for your attention !!**

Appendix:

Chang Chun Plastics: PHBA in Mailiao plant

* Process flowchart

